

# SOUND BYTE SYSTEMS INC

## INTERMIDI

### PIC-Micro-controller-based MIDI CONVERTER System for MIDITZER tm Application

#### OVERVIEW

The system is designed to accept voltage and switch closure input and convert this information into the appropriate MIDI messages understood by the PC-based MIDITZER tm 2-manual theatre organ. The most popular controls are included and the system is being released with two code versions for the stops – one for toggling momentary switches and the other for switches of the maintained variety.

#### CHANNELS USED

The default set of channels, controller numbers, and stops values have been implemented for the sake of standardization and simplicity —

Solo = Chan 1  
Acc = Chan 2  
Ped = Chan 3  
Aux = Chan 16 (PISTONS, EXP)



[Click for next page](#)

# SOUND BYTE SYSTEMS INC

## INTERMIDI

### INSTRUCTIONS

All KMI-2.00 opto-isolator boards are shipped with ribbon cable sets. These ribbons are to be separated, skinned and tinned before soldering to key switch and pedal switch contacts (positive 9-12 VDC). A return (ground wire) connection must be made to each opto-isolator board and these boards are then connected to their respective CPU boards.

[Click here to see attached drawing depicting the system overall connections.](#)

The DM1002 boards derive seven functions from three connections and utilize the leftover 62-63-64 opto-isolator inputs associated with the SOLO and ACCOM KMI-2.00 boards. These boards are equipped with a cable having seven pairs of conductors which, when shorted together, activate the respective function called out on the documentation which follows. A connection to the key switch BUS voltage is required to the pad so marked on the DM1002.

[Click here to see the connection drawing for the DM1002.](#)

PISTONS are to be passive switches, with no external voltages applied.

Expressions (Swells) and Crescendo Analog-to-Digital connections are ratio-metric with VCC, Ground and wiper potentiometer connections provided as .100" spaced headers. Here again, no external voltages are to be supplied. For excellent foot shoe-linkable potentiometers: —

[PETERSON ELECTRO-MUSICAL PRODUCTS, INC.](#)

[Click for next page](#)

# SOUND BYTE SYSTEMS INC

## INTERMIDI

### SECOND-TOUCH ISSUES

At this time, the system's key switch inputs make no provision for SECOND-TOUCH. However, a user supplying his or her own keyboards can still use the remaining portions of this very versatile system to control STOPS, PISTONS and EXPRESSIONS.

### HOW TO NAVIGATE THESE PAGES and DRAWINGS

These pages have been created using ADOBE ACROBAT CREATOR and have navigable links, recognizable either via:

[specially-colored and underlined text](#), or by items boxed-off in **RED**.

### INSTRUCTION UPDATES, IMPROVEMENTS and POSTINGS

Your suggestions, our own updates/improvements will be considered for future releases. A vital and dynamic copy of these instructions in PDF format will shortly be posted at:

<http://www.intermidi.com/miditzer>

**ACKNOWLEDGEMENTS:** Special appreciation to Jim Henry for awesome MIDITZER tm S/W.  
Thank Greg Carnes of KOHN MUSIC for being or first brave buyer.

[CLICK TO GO TO DRAWINGS NOW](#)

to DM1002 Diode Matrix

from Manual Switches and DM1002 Matrix

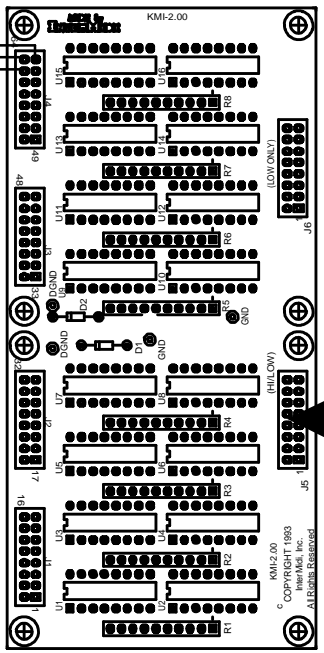

DIP/JPR Connections

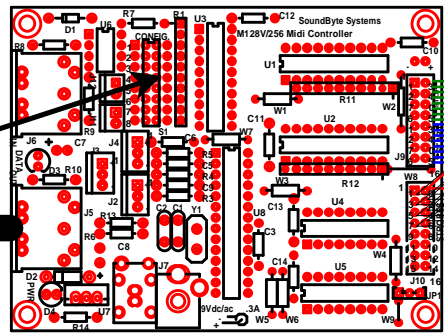

Pedal Switches & Stops CPU (with Solo & Pedal Pistons)

opto connectors

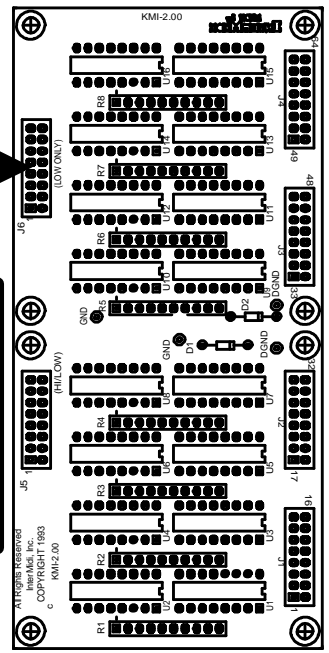

to DM1002 Diode Matrix

from Manual Switches and DM1002 Matrix

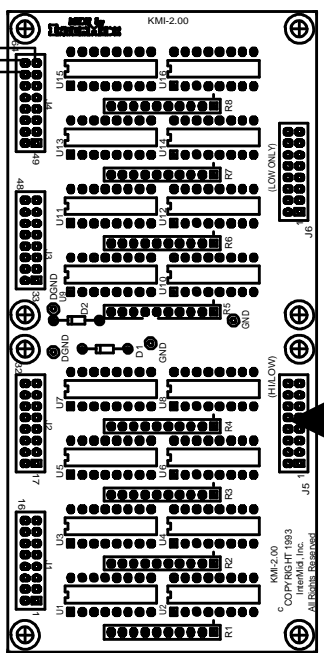

DIP/JPR Connections

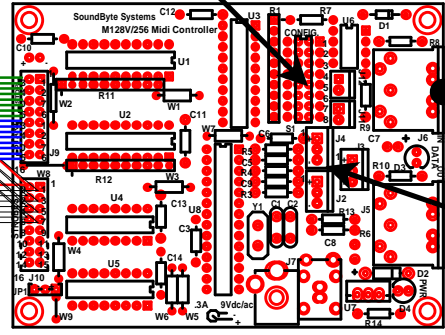

Solo & Acc Manl + Pistons CPU

MIDI-MERGER such-as MIDI SOLUTIONS 2 by 1 (line-powered)

Expressions, Crescend

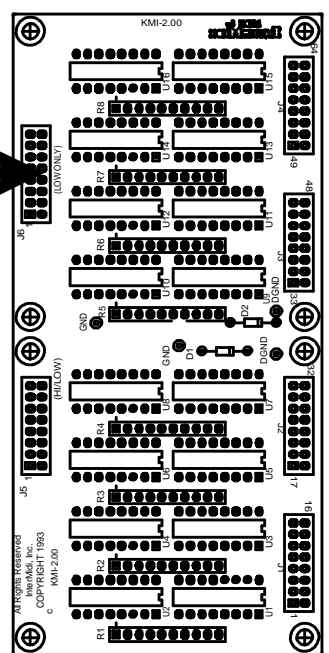

from Pedal Switches and 9 Stop Switches

To MIDI-MERGER™ - equipped PC

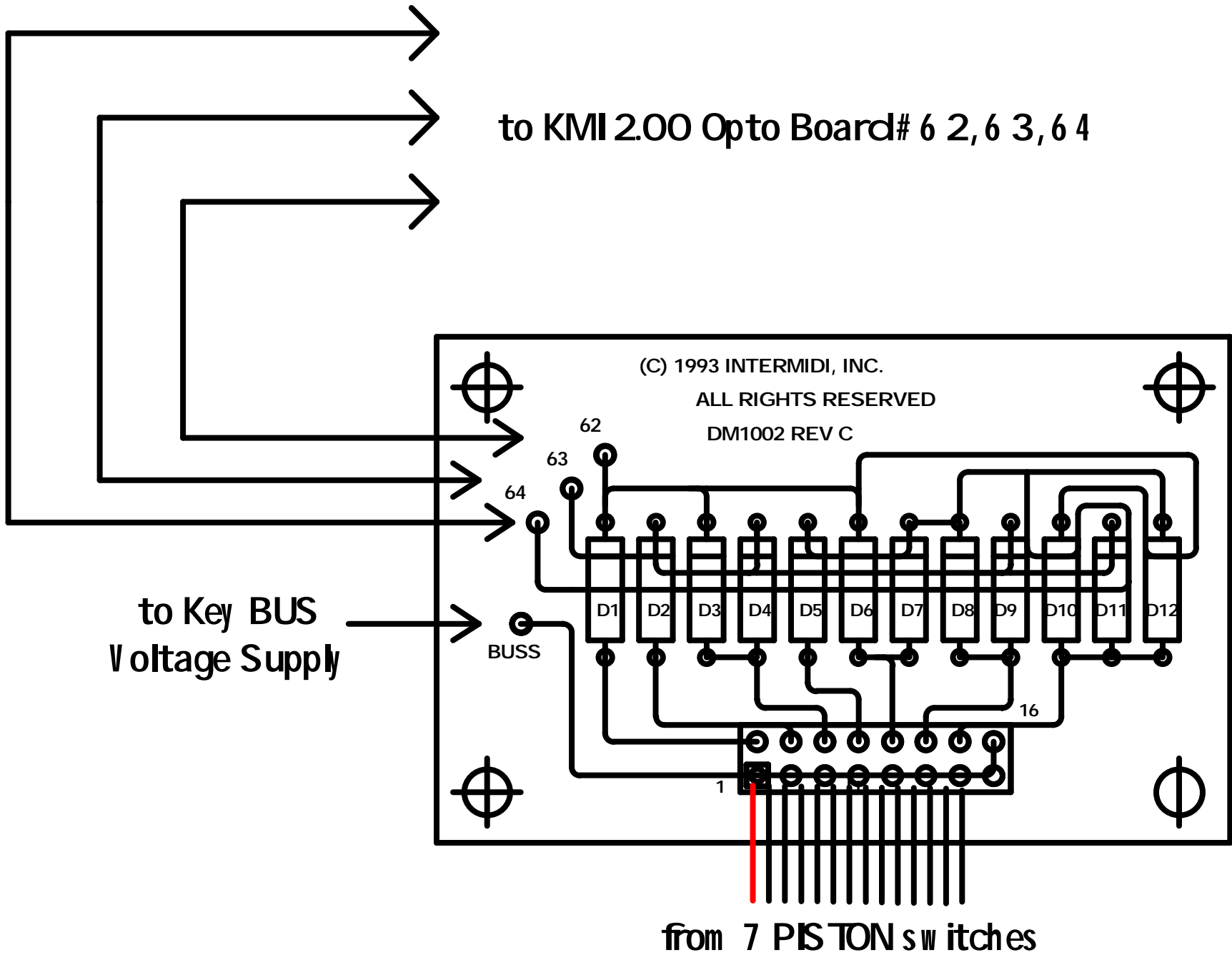

## "ORGAN STOPS" wired to OPTO inputs

PEDAL  
upper  
opto

SOLO	Chan	opto 1					ACCOM	opto 1					PEDAL	PEDAL upper opto				
		ON	INPUT	OFF	ON	INPUT		OFF	ON	INPUT	OFF	ON		INPUT	OFF			
16 TUBA	16	81	0	<b>1</b>	80	0	16 VIOL	81	35	<b>36</b>	80	35	16 TUBA	81	70	<b>39</b>	80	70
16 BOUR	16	81	1	<b>2</b>	80	1	8 HORN	81	36	<b>37</b>	80	36	16 DIA	81	71	<b>40</b>	80	71
16 VIOL	16	81	2	<b>3</b>	80	2	8 TUBA	81	37	<b>38</b>	80	37	16 BOUR	81	72	<b>41</b>	80	72
8 HORN	16	81	3	<b>4</b>	80	3	8 DIA	81	38	<b>39</b>	80	38	8 TUBA	81	73	<b>42</b>	80	73
8 TUBA	16	81	4	<b>5</b>	80	4	8 TIBIA	81	39	<b>40</b>	80	39	8 DIA	81	74	<b>43</b>	80	74
8 DIA	16	81	5	<b>6</b>	80	5	8 CLAR	81	40	<b>41</b>	80	40	8 TIBIA	81	75	<b>44</b>	80	75
8 TIBIA	16	81	6	<b>7</b>	80	6	8 OBOE	81	41	<b>42</b>	80	41	8 CLAR	81	76	<b>45</b>	80	76
8 CLAR	16	81	7	<b>8</b>	80	7	8 VIOL	81	42	<b>43</b>	80	42	8 CELLO	81	77	<b>46</b>	80	77
8 OBOE	16	81	8	<b>9</b>	80	8	8 CLST	81	43	<b>44</b>	80	43	8 FLUTE	81	78	<b>47</b>	80	78
8 VIOL	16	81	9	<b>10</b>	80	9	8 FLUTE	81	44	<b>45</b>	80	44	8 HORN	81	79	<b>48</b>	80	79
8 CLST	16	81	10	<b>11</b>	80	10	8 VOX	81	45	<b>46</b>	80	45	ACC-PED	81	80	<b>49</b>	80	80
8 FLUTE	16	81	11	<b>12</b>	80	11	4 VIOL	81	46	<b>47</b>	80	46	T1	81	81	<b>50</b>	80	81
8 VOX	16	81	12	<b>13</b>	80	12	4 CLST	81	47	<b>48</b>	80	47	T2	81	82	<b>51</b>	80	82
4 TUBA	16	81	13	<b>14</b>	80	13	4 FLUTE	81	48	<b>49</b>	80	48	T3	81	83	<b>52</b>	80	83
4 OCT	16	81	14	<b>15</b>	80	14	4 VOX	81	49	<b>50</b>	80	49	T4	81	84	<b>53</b>	80	84
4 TIBIA	16	81	15	<b>16</b>	80	15	2-2/3 12th	81	50	<b>51</b>	80	50	T5	81	85	<b>54</b>	80	85
4 VIOL	16	81	16	<b>17</b>	80	16	2 PICC	81	51	<b>52</b>	80	51	T6	81	86	<b>55</b>	80	86
4 CLST	16	81	17	<b>18</b>	80	17	HARP	81	52	<b>53</b>	80	52	BASS DR	81	87	<b>56</b>	80	87
4 FLUTE	16	81	18	<b>19</b>	80	18	MRIM	81	53	<b>54</b>	80	53	KETTLE DR	81	88	<b>57</b>	80	88
2-2/3 12th	16	81	19	<b>20</b>	80	19	CHRY	81	54	<b>55</b>	80	54	CRSH CYM	81	89	<b>58</b>	80	89
2 15th	16	81	20	<b>21</b>	80	20	SN DRUM	81	55	<b>56</b>	80	55	CYM	81	90	<b>59</b>	80	90
2 PICC	16	81	21	<b>22</b>	80	21	TAM	81	56	<b>57</b>	80	56	MAIN TR	81	91	<b>60</b>	80	91
1-3/5 TIER	16	81	22	<b>23</b>	80	22	CAST	81	57	<b>58</b>	80	57	SOLO TR	81	92	<b>61</b>	80	92
HARP	16	81	23	<b>24</b>	80	23	BLCK	81	58	<b>59</b>	80	58	VOX TR	81	93	<b>62</b>	80	93
MRIM	16	81	24	<b>25</b>	80	24	SL BELL	81	59	<b>60</b>	80	59	TUBA TR	81	94	<b>63</b>	80	94
CHIME	16	81	25	<b>26</b>	80	25	OCT	81	60	<b>61</b>	80	60	TIBIA TR	81	95	<b>64</b>	80	95
XYLO	16	81	26	<b>27</b>	80	26	SOLO-ACC	81	61	<b>62</b>	80	61						
CHRY	16	81	27	<b>28</b>	80	27	8 HORN	81	62	<b>63</b>	80	62						
GLOCK	16	81	28	<b>29</b>	80	28	8 TUBA	81	63	<b>64</b>	80	63						
BELLS	16	81	29	<b>30</b>	80	29	4 TIBIA	81	64	<b>33</b>	80	64						
SUB	16	81	30	<b>31</b>	80	30	MRIM	81	65	<b>34</b>	80	65						
UN OFF	16	81	31	<b>32</b>	80	31	CHIME	81	66	<b>35</b>	80	66						
OCT	16	81	32	<b>33</b>	80	32	GLCK	81	67	<b>36</b>	80	67						
16 TUBA	16	81	33	<b>34</b>	80	33	TRNGL	81	68	<b>37</b>	80	68						
8 CLAR	16	81	34	<b>35</b>	80	34	SOLO-ACC	81	69	<b>38</b>	80	69						

*Two Versions available - Maintained & Mom*

<<<<<< Pedal UPPER OPTO wiring starts here #33

## ORGAN "PISTONS"

		(Manuals Processor)	PROG CH - CH 16			(Pedals/Stops Processor)	PROG CH - CH 16
<b>DIP-JPR</b>	1-2	<b>BASS COUPLER</b>		<b>DIP-JPR</b>	1-2	<b>SOLO 1</b>	5
	3-4	<b>ACCOM 1</b>	16		3-4	<b>SOLO 2</b>	6
	5-6	<b>ACCOM 2</b>	17		5-6	<b>SOLO 3</b>	7
	7-8	<b>ACCOM 3</b>	18		7-8	<b>SOLO 4</b>	8
	9-10	<b>ACCOM 4</b>	19		9-10	<b>SOLO 5</b>	9
	11-12	<b>ACCOM 5</b>	20		11-12	<b>PED 1</b>	20
	13-14	<b>NOTE-BUSTER</b>			13-14	<b>PED 2</b>	21
	15-16	<b>TRANSPOSE</b>			15-16	<b>PED 3</b>	22
<b>DM-1002</b>	1-2	<b>SET</b>	126	<div style="border: 1px solid black; padding: 10px; width: fit-content; margin: auto;"> <p>© 2007 Sound Byte Systems, Inc.  MIDITZER™ MIDI Converter System  Wiring Tables for DIP/JPR &amp; DM1002  MIDITZER is not a trademark of  Sound Byte Systems, Inc.</p> </div>			
	3-4	<b>SOLO</b>	122				
	5-6	<b>MEM</b>	127				
	7-8	<b>RES</b>	123				
	9-10	<b>ACC</b>	121				
	11-12	<b>CAN</b>	124				
	13-14	<b>MAP</b>	125				
<b>DM-1002</b>	1-2	<b>PED</b>	120				
	3-4	<b>TRM</b>	119				
	5-6	<b>p</b>	0				
	7-8	<b>mf</b>	1				
	9-10	<b>f</b>	2				
	11-12	<b>ff</b>	3				
	13-14	<b>fff</b>	4				

• ACCOMP •

4 VIOL 4 CLST 4 FLUTE 4 VOX 2 2/3 12th 2 PICC HARP MRIM CHRY OCT SOLO TO ACC

• MAIN SOLO CRES •

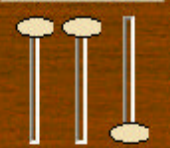

• SOLO •

4 TUBA 4 OCT 4 TIBIA 4 VIOL 4 CLST 4 FLUTE 2 2/3 12th 2 15th 2 PICC 1 3/5 TIERC

16 VIOL 8 HORN 8 TUBA 8 DIA 8 TIBIA 8 CLAR 8 OBOE 8 VIOL 8 CLST 8 FLUTE 8 VOX

8 HORN 8 TUBA 8 DIA 8 TIBIA 8 CLAR 8 OBOE 8 VIOL 8 CLST 8 FLUTE 8 VOX

MIDITZER

• ACCOMP. SECOND TOUCHES •

8 HORN 8 TUBA 4 TIBIA MRIM CHIME GLCK TRNGL SOLO ACC

• SOLO SECOND TOUCHES •

16 TUBA 8 CLAR

16 TUBA 16 BOUR 16 VIOL

• PEDAL •

BASS DRUM KETTL DRUM CRSH CYMB CYMB ACC PED



SET p mf f ff fff 1 2 3 4 5 SOL MEM

HARP MRIM CHIME XYLO CHRY

8 TIBIA 8 CLAR 8 CELLO 8 FLUTE 8 HORN

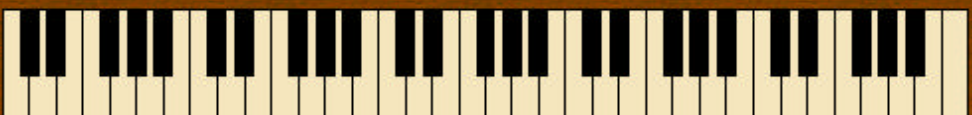

RES pp p mf f ff 1 2 3 4 5 ACC CAN

SUB UNISN OFF OCT GLOCK BELLS

16 TUBA 16 DIA 16 BOUR 8 TUBA 8 DIA

1 2 3 T1 T2 T3 T4 T5 T6 MAP PED TRM

• TREMULANTS •

MAIN SOLO VOX TUBA TIBIA

• COMBINATION MEMORY •

0	1	2	3	4	5	6	7	8	9
0	1	2	3	4	5	6	7	8	9



**MIDITZER<sup>tm</sup> PROCESSOR FOR TWO MANUALS**

		MIDITZER Function	J Number
A-D 0	VOL-CTRL 7	SW SOLO	J4
A-D 1	EXP-CTRL 11	SW MAIN	J3
A-D 2	CRESC-CTRL 1	CRESCENDO	J2
A-D 3	BASS CPLR LED		
A-D 4	TRANSPOSE LED		

**MIDITZER<sup>tm</sup> PROCESSOR FOR PEDALS & STOPS**

		MIDITZER Function	J Number
A-D 0	Transpose Switch Input		J4
A-D 1	TRANSPOSE LED		J3
A-D 2			J2
A-D 3			
A-D 4			

*Pin 2 must tie to VCC thru 10K pullup; pin 3 is GND; pin 1 is VCC*

*Pin 1 is ANODE; Pin 2 is CATHODE*